

THIS DRAWING IS UNPUBLISHED. RELEASED FOR PUBLICATION
 © COPYRIGHT BY TYCO ELECTRONICS CORPORATION. ALL RIGHTS RESERVED.

LOC	DIST	REVISIONS			
P	LTR	DESCRIPTION	DATE	DWN	APVD
GP	00	0	RELEASED PER EC 0S13-0207-05	27JUN05	SW JG

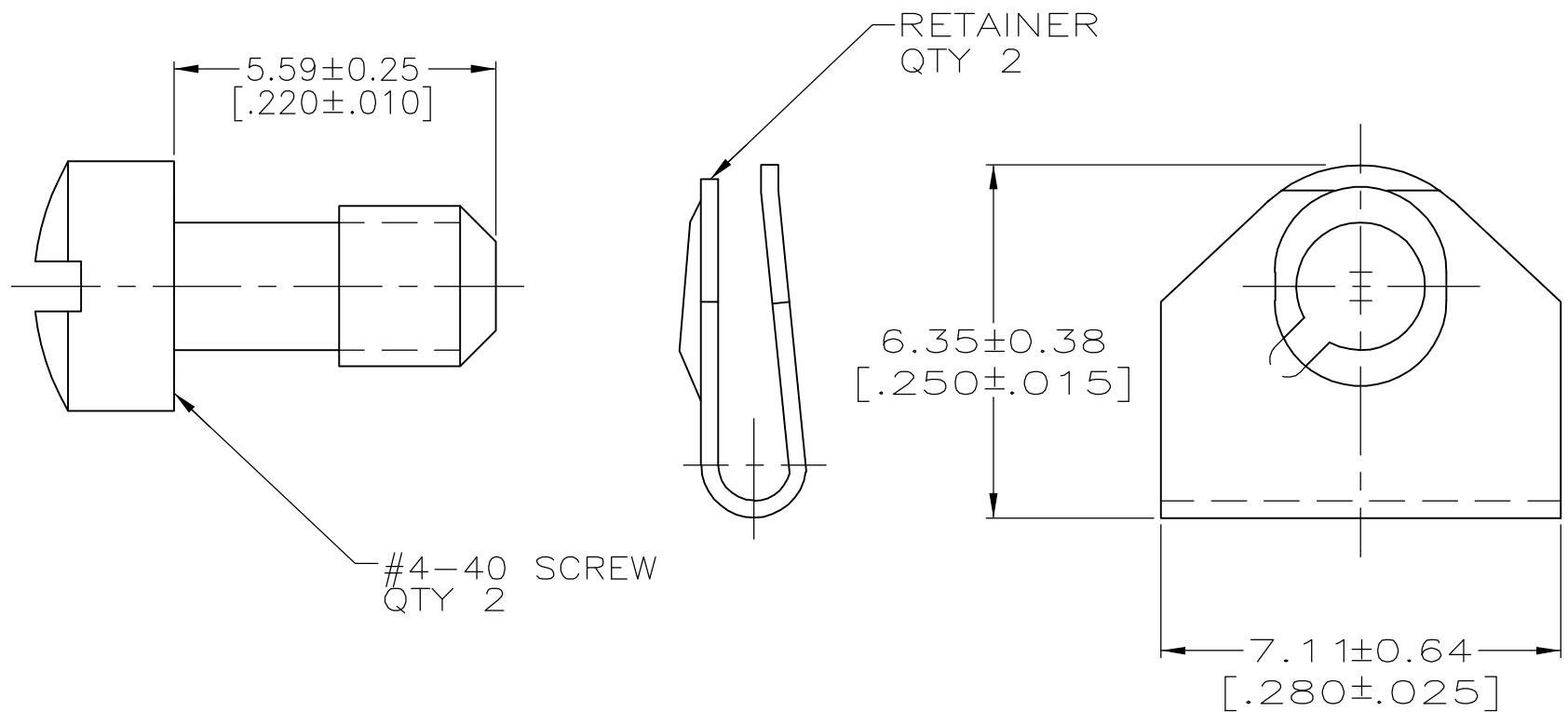

- 1. PARTS PACKAGED UNASSEMBLED.
- 2. STAINLESS STEEL PER ASTM A666.
- 3. PACKAGING MARKED WITH TYCO, PART NO & DATE CODE.
- 4. ZINC PLATED .000200-.000400 THICK YELLOW CHROMATE COATING.
- 5. ZINC PLATED .000200-.000400 THICK CLEAR CHROMATE COATING.
- 6. PARTS INDIVIDUALLY BULK PACKED AND SHIPPED AS A UNIT PACKAGE.
- 7. PARTS PACKAGED AS A UNIT KIT.

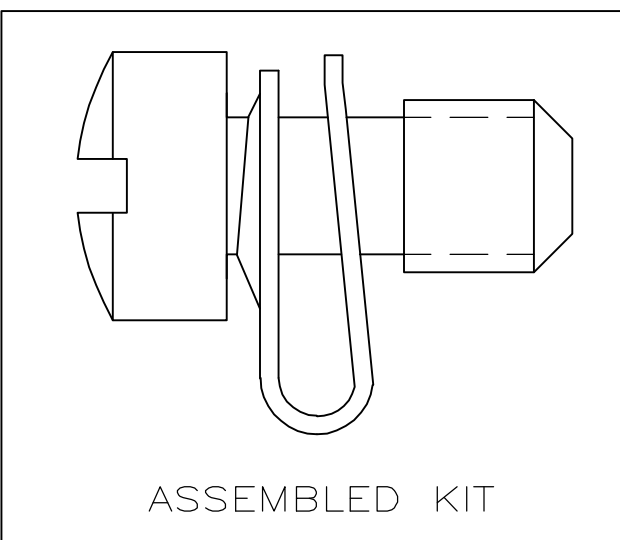

3	6	5	5205980-5
3	7	5	5205980-4
3	6	4	5205980-3
3	7	4	5205980-1
MARKING	PACKAGING	SCREW FINISH	PART NO

THIS DRAWING IS A CONTROLLED DOCUMENT.		DWN S.WAITMAN 27JUN05	Tyco Electronics Corporation Harrisburg, Pa 17105-3608		
DIMENSIONS: mm [INCHES]		CHK C.ROHDE 27JUN05			
TOLERANCES UNLESS OTHERWISE SPECIFIED:		APVD M.WALMSLEY 27JUN05	NAME -		
0 PLC ± - 1 PLC ± - 2 PLC ± 0.13 [.005] 3 PLC ± - 4 PLC ± - ANGLES ± -		PRODUCT SPEC -	KIT, SCREW RETAINER		
MATERIAL SCREWS: CARBON STEEL		APPLICATION SPEC -	SIZE A3	CAGE CODE 00779	DRAWING NO C-5205980
RETAINERS: 2		FINISH SCREWS: -SEE TABLE	WEIGHT -	RESTRICTED TO -	
CUSTOMER DRAWING			SCALE 8:1	SHEET 1 OF 1	REV 0